

A-A (1:2)

B-B (1:2)

C-C (1:2)

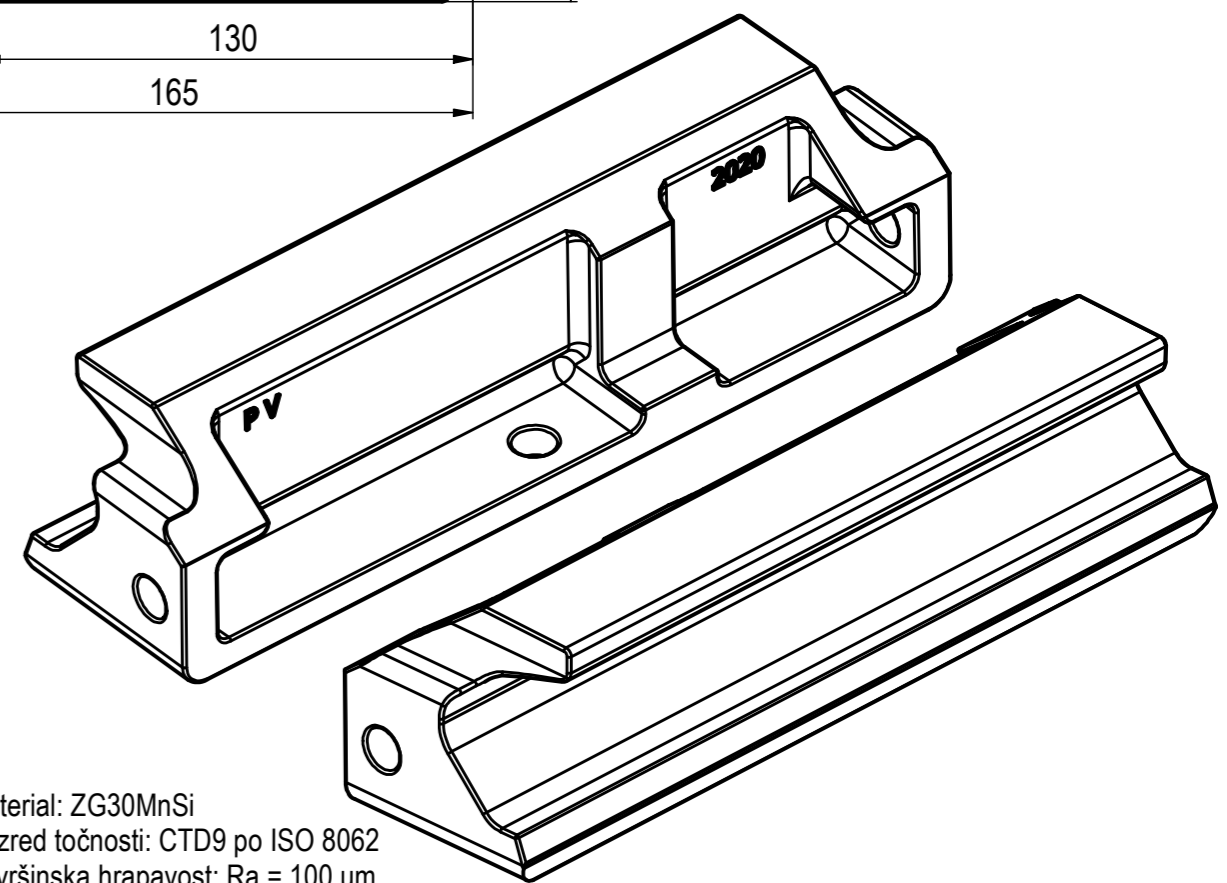
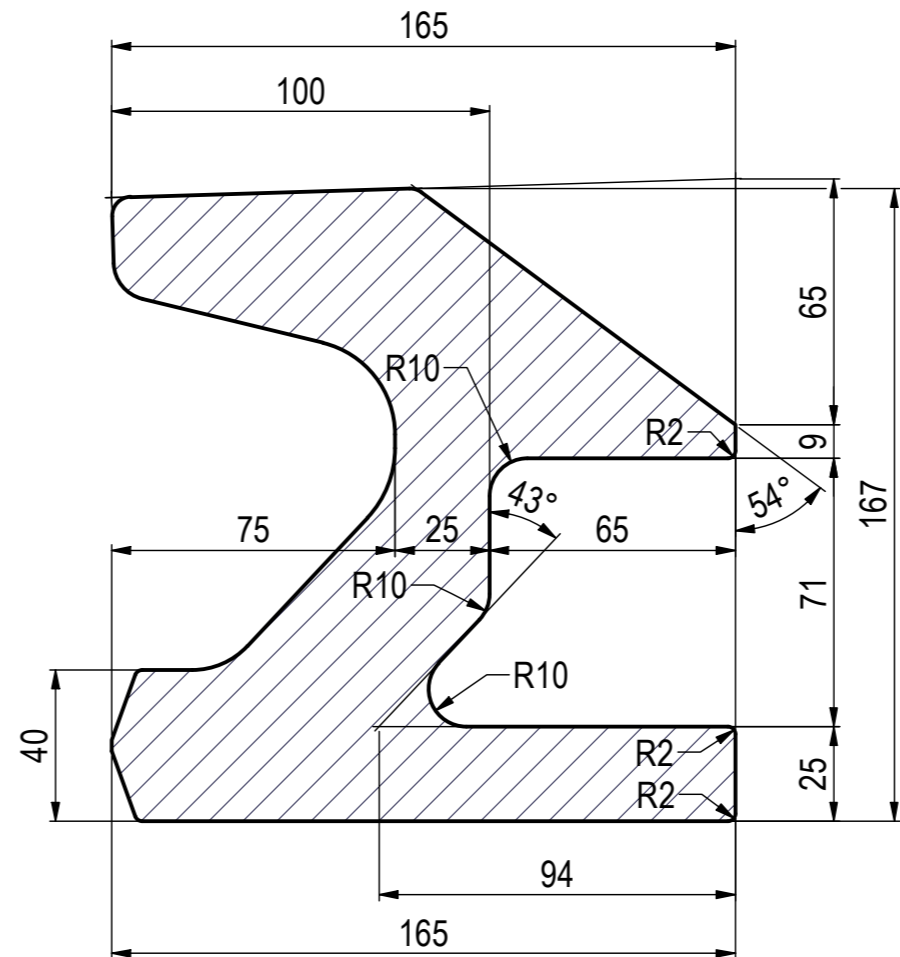
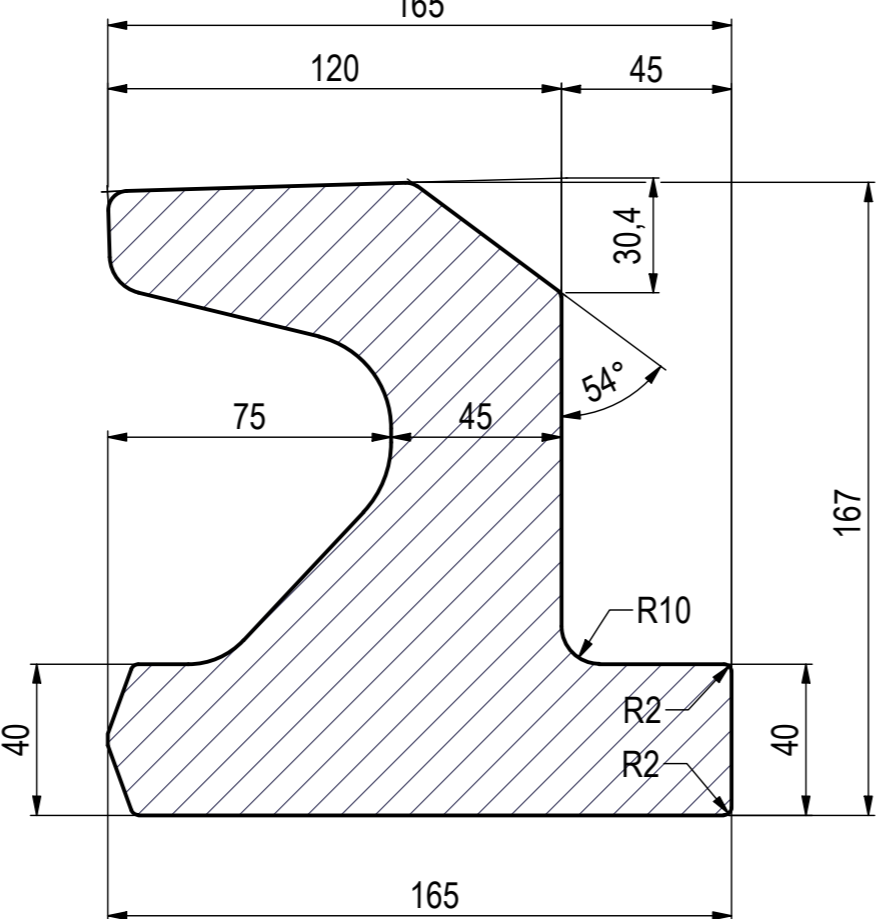
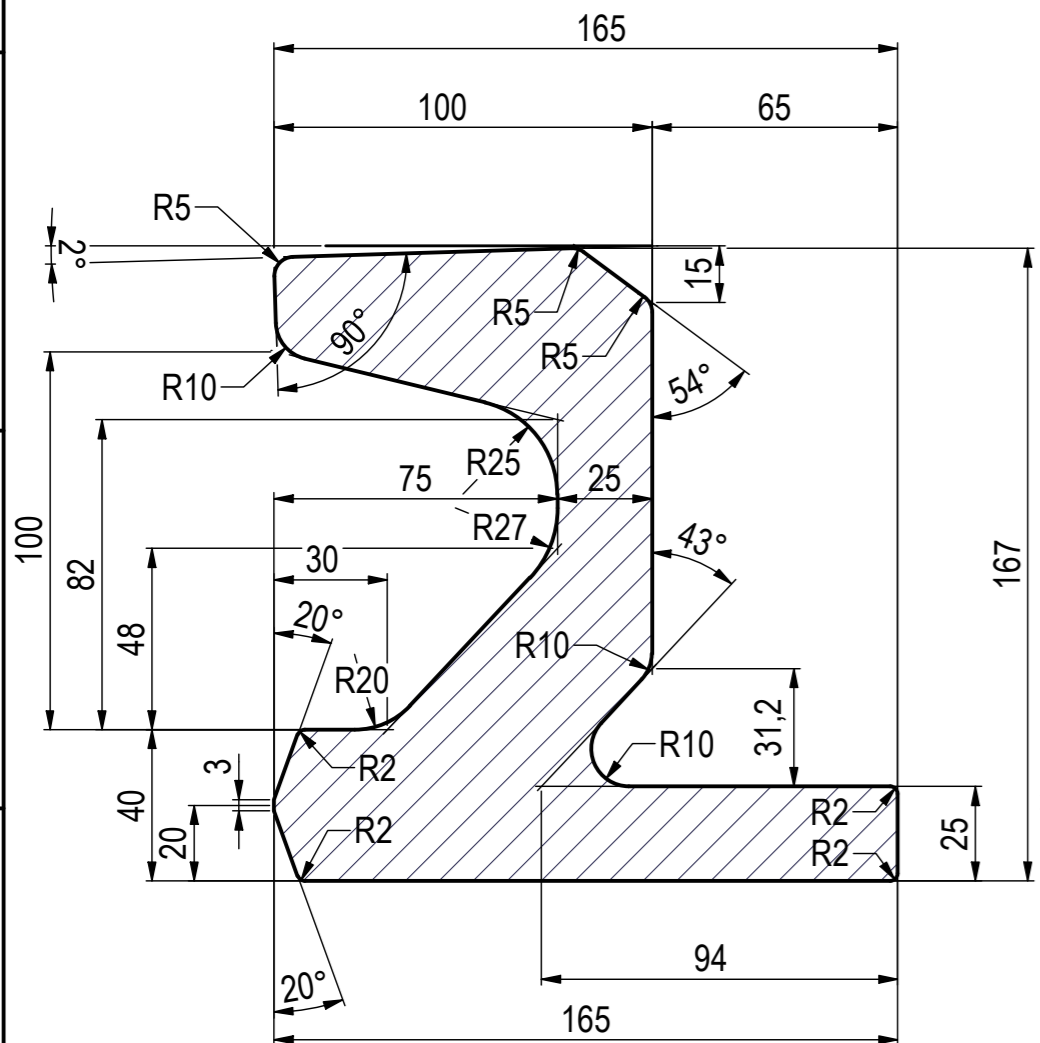

Material: ZG30MnSi
 Razred točnosti: CTD9 po ISO 8062
 Površinska hrapavost: Ra = 100 um
 Toplotna obd.: Poboljšano na od 270 do 290 HB
 Stanje: Očiščen jekleni odlitek brez meh. obdelave

P.obdelava:	Term.obd.:	Masa: 65.3 kg	Št.artikla:	Izdela:	Miro Tisnikar, inž.str.
P.zaščita:	Odst.net.mer: SIST DIN 7186 T1	Gradivo:	Opomba:	Risal:	Miro Tisnikar, inž.str.
Naslov:	E-profil 165 x 167 x 650		Št.risbe:	102-2-8438	
PREMOGOVNIK VELENJE STROJNA PRIPRAVA DELA			Spada k: 202-2-8437		
Datum: Avgust 2020	Merilo: 1:2,5	List: 1	Št.l.:	1	Št. priloge: