

1

2

3

4

5

6

7

8

A

B

C

D

E

F

E-E (1:2)

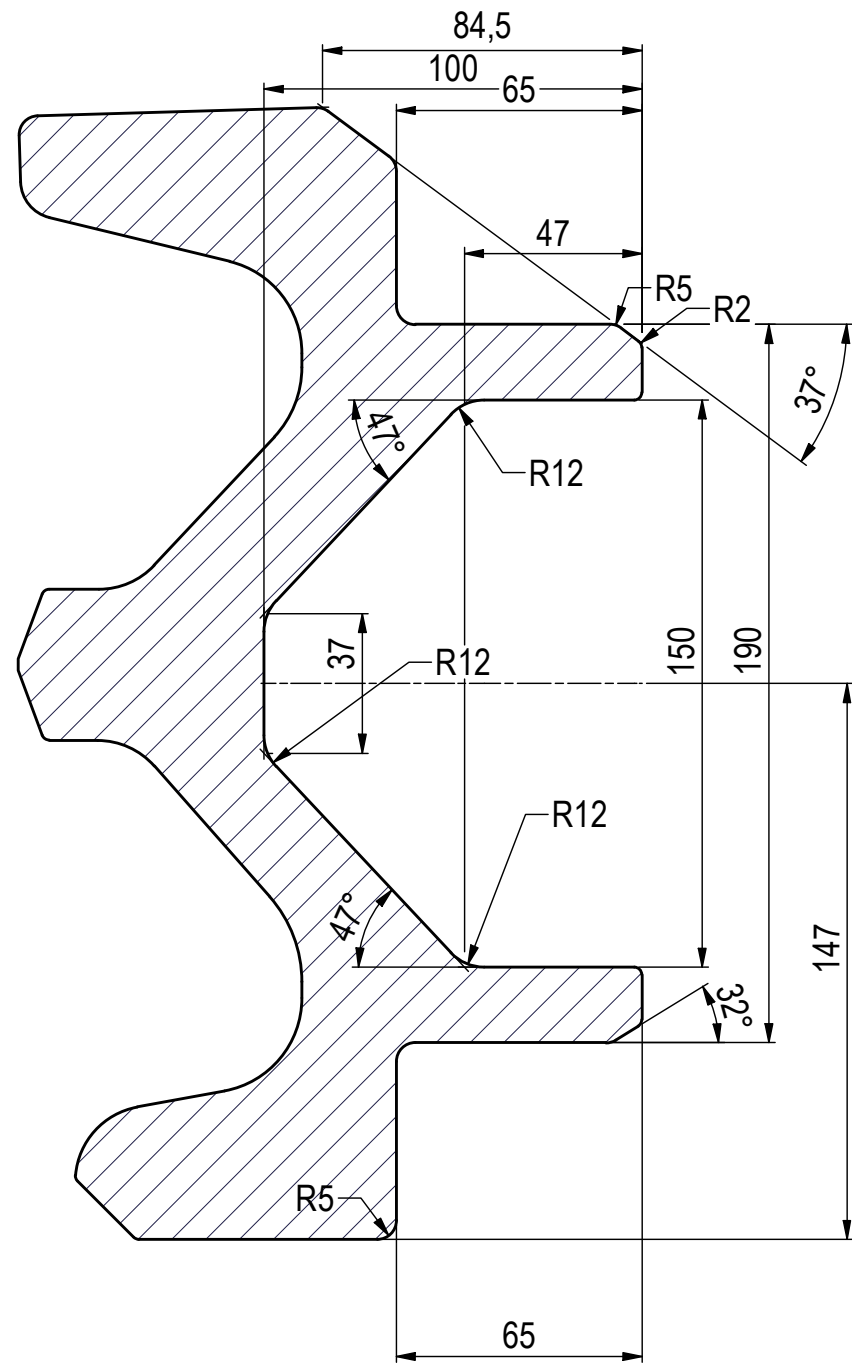

F-F (1:2)

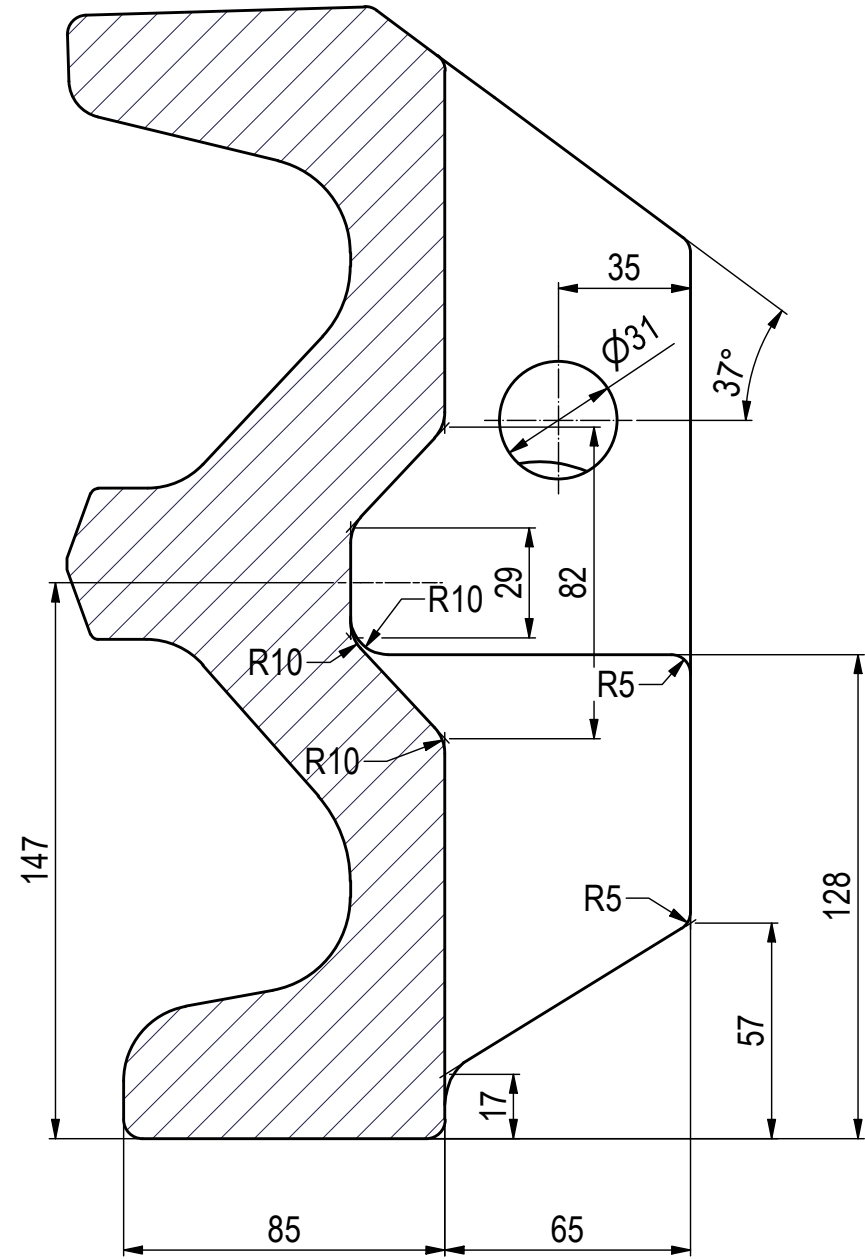

G-G (1:2)

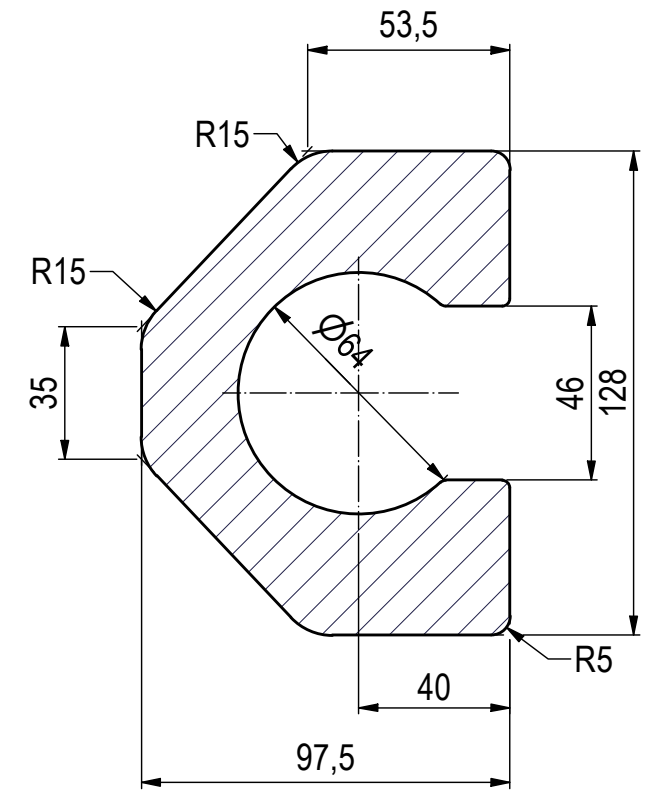

A-A (1:5)

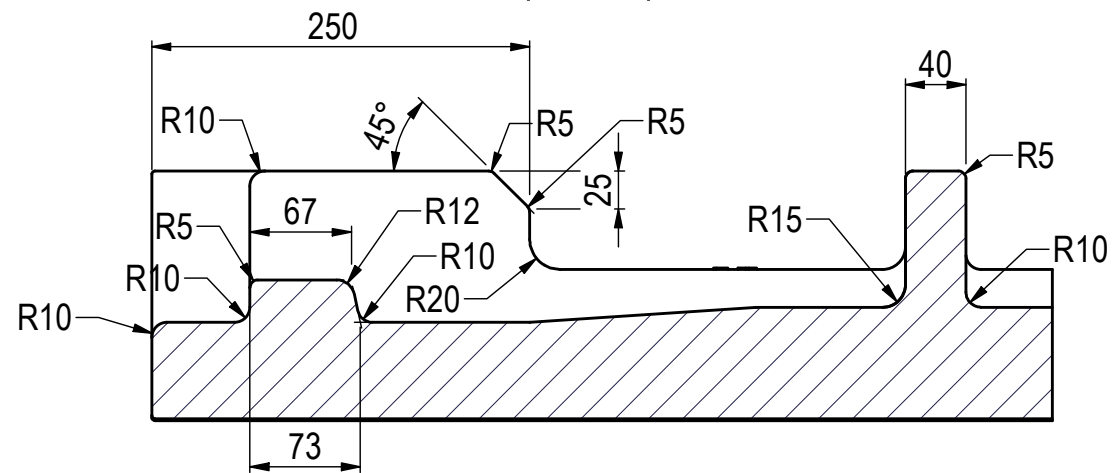

P.obdelava:	Term.obd.:	Masa: 254,6 kg	Št.artikla:		Izdelal:	Aleksander JORDAN, univ.dipl.inž.str.			
P.zaščita:	Odst.net.mer: SIST DIN 7186 T1	Gradivo:	Opomba:		Risal:	Aleksander JORDAN, univ.dipl.inž.str.			
Naslov:	Σ profil - PV_165 x 300 x 1747				Št.risbe:	102 - 2 - 8430			
PREMOGOVNIK VELENJE STROJNA PRIPRAVA DELA					Spada k:	202 - 2 - 8433			
					Datum:	Merilo:	List:	Št.l.:	Št.priloge:
D:\inventor-delovna\Designs\odkopni-transporter\E-profil\E-profil-odlitek\Σ-profil_165 x 300 x 1747.idw					August 2020	1:5	2	3	

1

2

3

4

5

6

7

8

A

B

C

D

E

F

1

2

3

4

5

6

7

8

A

B

C

D

E

F

A

B

C

D

E

F

L-L (1:5)

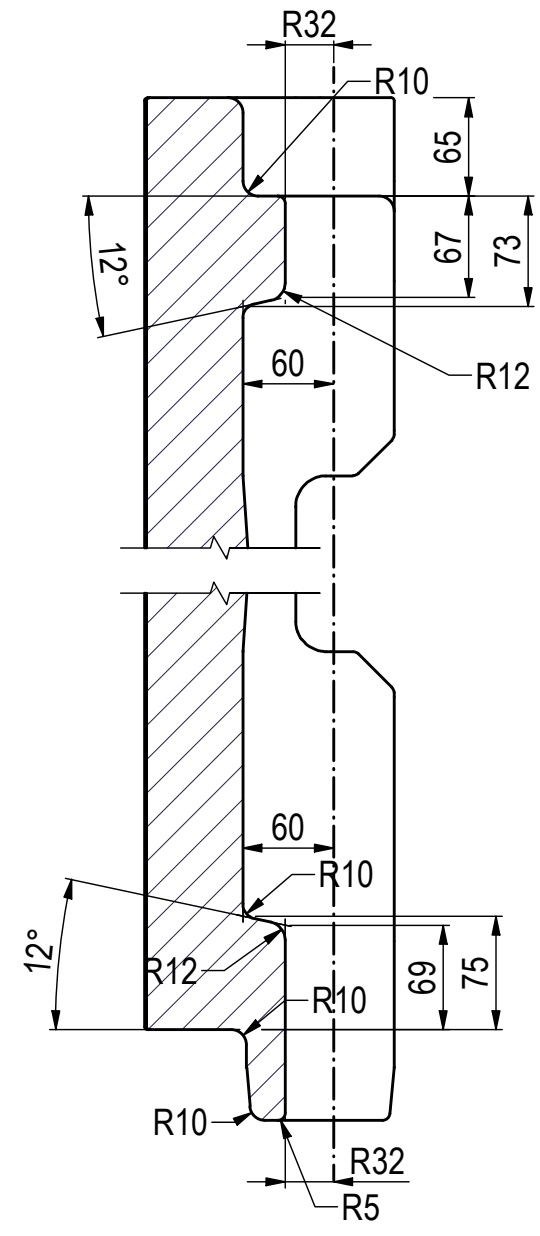

M-M (1:5)

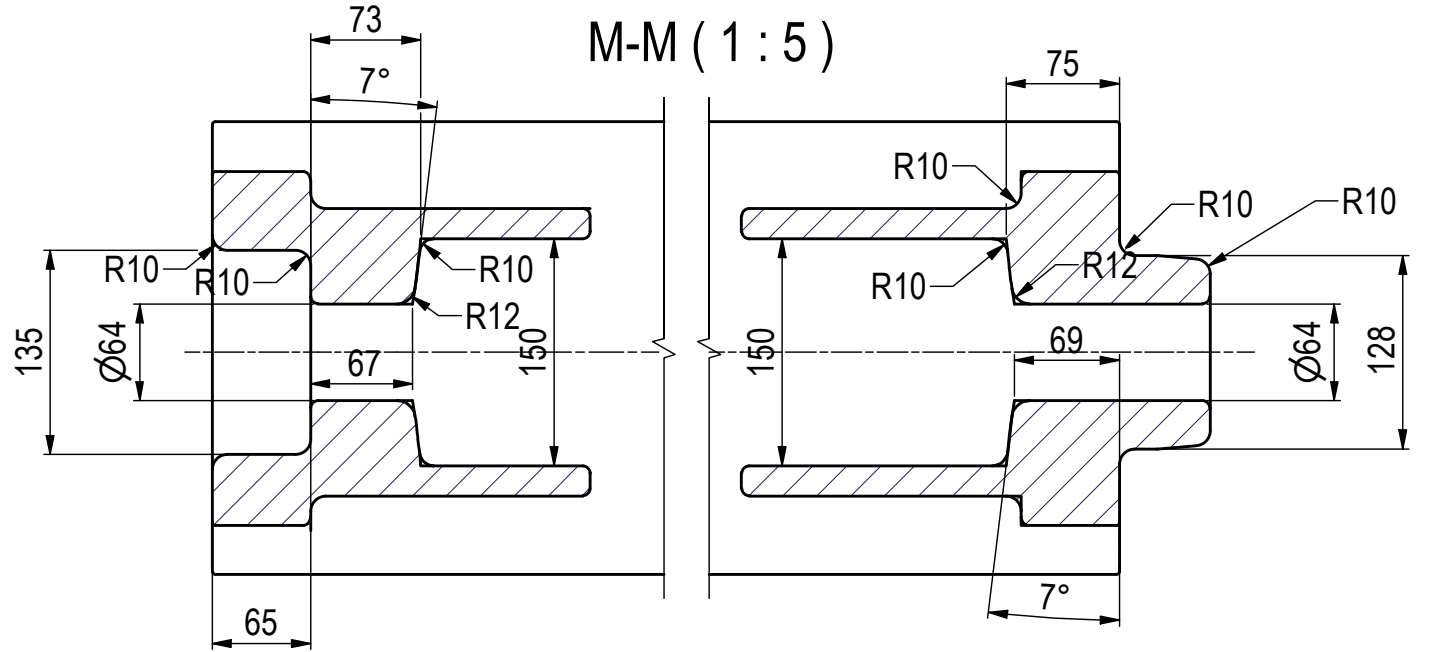

N-N (1:5)

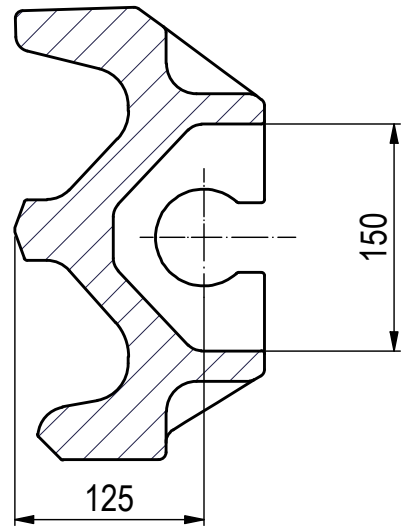

P-P (1:5)

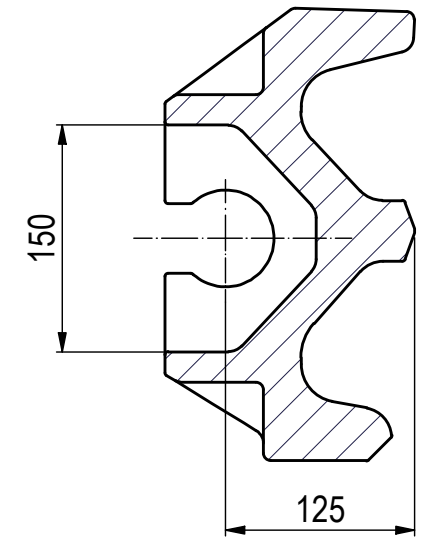

P.obdelava:	Term.obd.:	Masa: 254,6 kg	Št.artikla:		Izdelal:	Aleksander JORDAN, univ.dipl.inž.str.			
P.zaščita:	Odst.net.mer: SIST DIN 7186 T1	Gradivo:	Opomba:		Risal:	Aleksander JORDAN, univ.dipl.inž.str.			
Naslov: Σ profil - PV_165 x 300 x 1747					Št.risbe: 102 - 2 - 8430				
					Spada k: 202 - 8433				
PREMOGOVNIK VELENJE STROJNA PRIPRAVA DELA					Datum: Avgust 2020	Merilo: 1:5	List: 3	Št.l.: 3	Št.priloge:

D:\inventor-delovna\Designs\odkopni-transporter\E-profil\E-profil-odlitek\Σ-profil_165 x 300 x 1747.idw

1

2

3

4

5

6

7

8